

Installation Instruction - SLHB LED High Bay

Warning, cautions and operating instructions

- To reduce the risk of death, personal injury or property damage from fire, electric shock, falling parts, cuts, abrasions, and other hazards read all warnings and instructions included with and on the fixture box and all fixture labels.
- Commercial installation, service and maintenance of luminaires should be performed by a qualified licensed electrician.
- For The installation: If you are unsure about the installation or maintenance of the luminaires, consult a qualified licensed electrician and check your local electrical code.
- To prevent wiring damage or abrasion, do not expose wiring to edges of sheet metal or other sharp objects.
- Do not make or alter any open holes in an enclosure of wiring or electrical components during kit installation.
- In order to use this product more efficiently and safely, please clean and check it regularly (once every six months).

Warning: Risk of fire or electrical shock

- Turn off electrical power at fuse or circuit breaker box before wiring fixture to the power supply.
- Turn off the power when you perform any maintenance.
- Verify that supply voltage is correct by comparing it with the luminaire label information.
- Make all electrical and grounded connections in accordance with the National Electrical Code and any applicable local code requirements.
- All wiring connections should be capped with UL approved wire connectors.

Caution: Risk of injury

- Avoid direct eye exposure to the light source while it is on.
- Account for small parts and destroy packing material, as these may be hazardous to children.

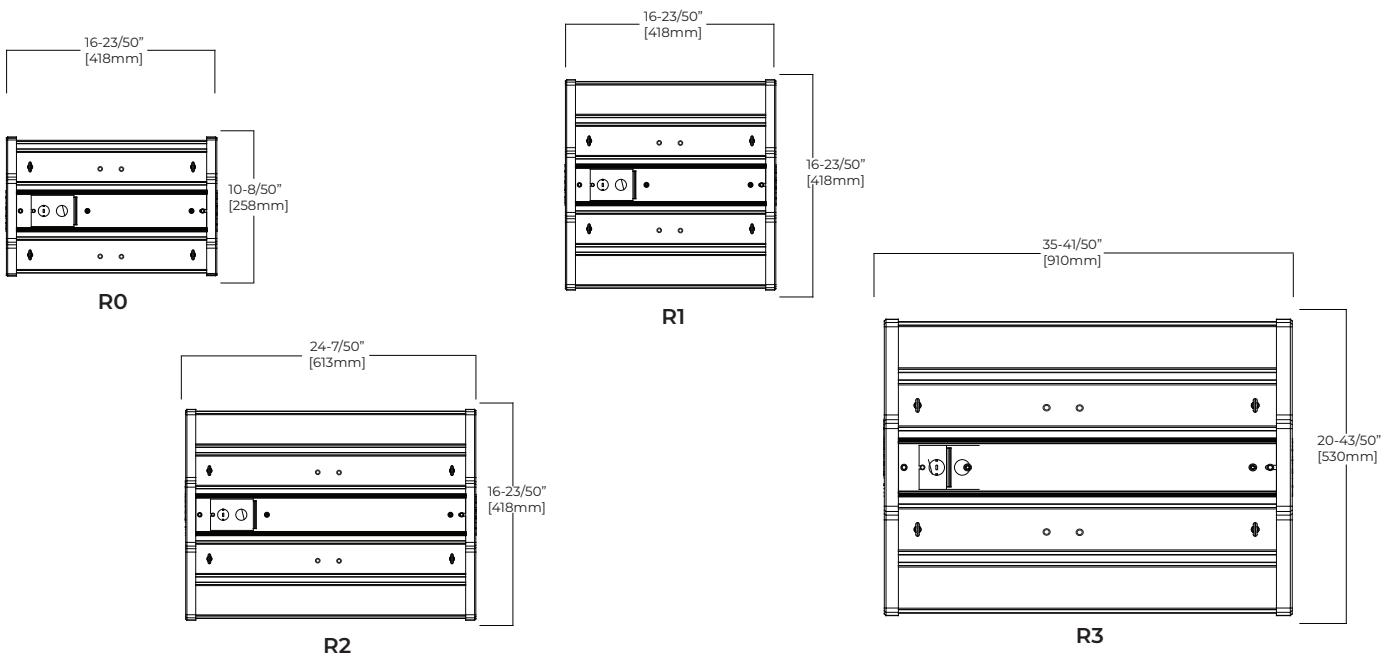

Installation Instruction - SLHB LED High Bay

Handling Locations

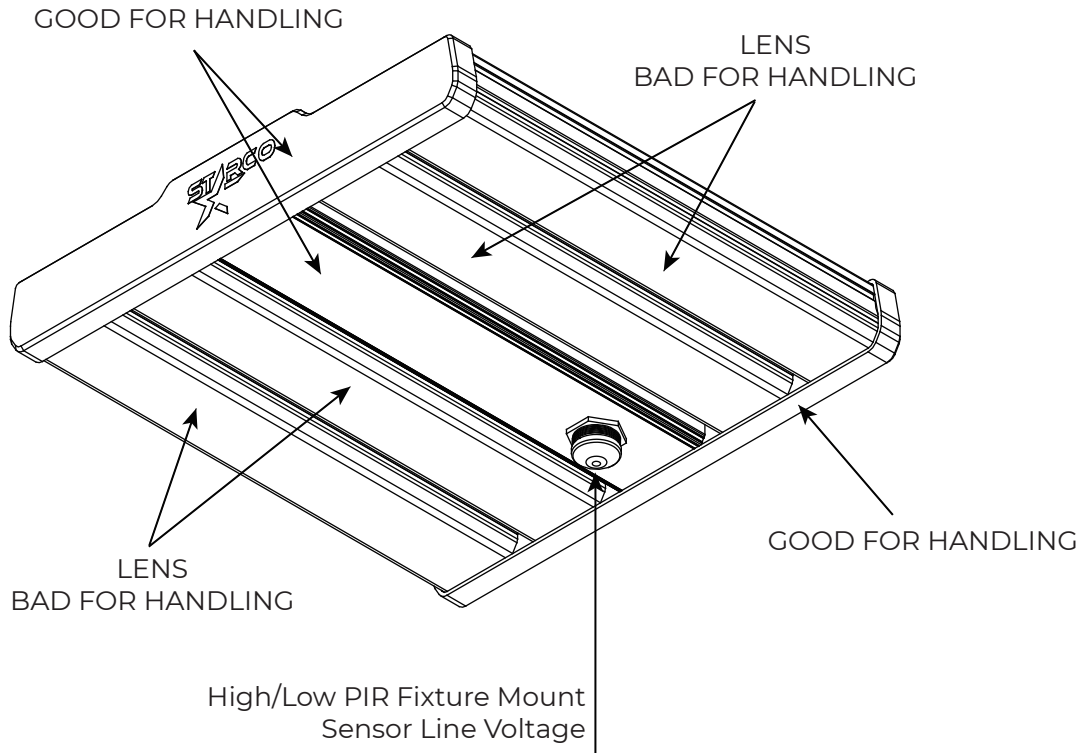

SLHB with 480V Autotransformer Case or Battery

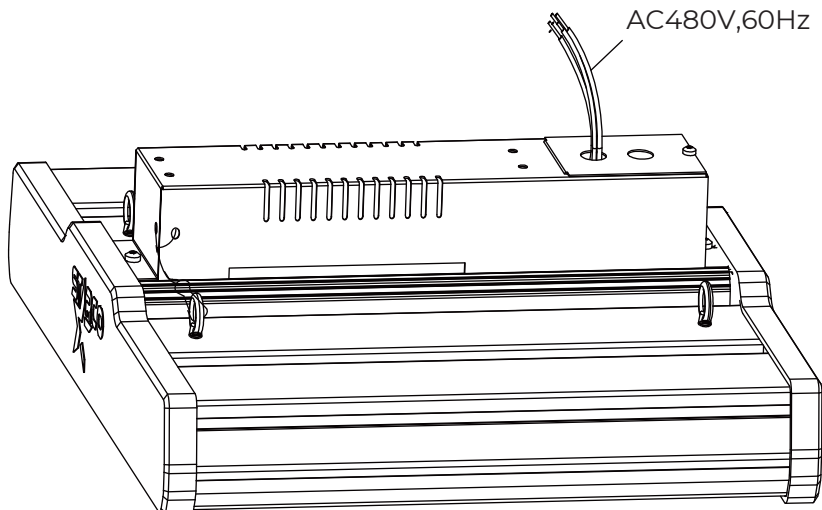

Installation Instruction - SLHB LED High Bay

Installation using aircraft cable

Always turn off the power first.

1. Pull the screws off the back plate of the fixture.
2. Install the autotransformer case (optional) if applicable to the back plate using the screws and connect the safe cable to one of the mounting ring. And connect the plug between autotransformer and the fixture.
3. Connect the aircraft cable to the fixture.
4. Connect the power cord to the wires in the autotransformer case (optional) or the fixture.

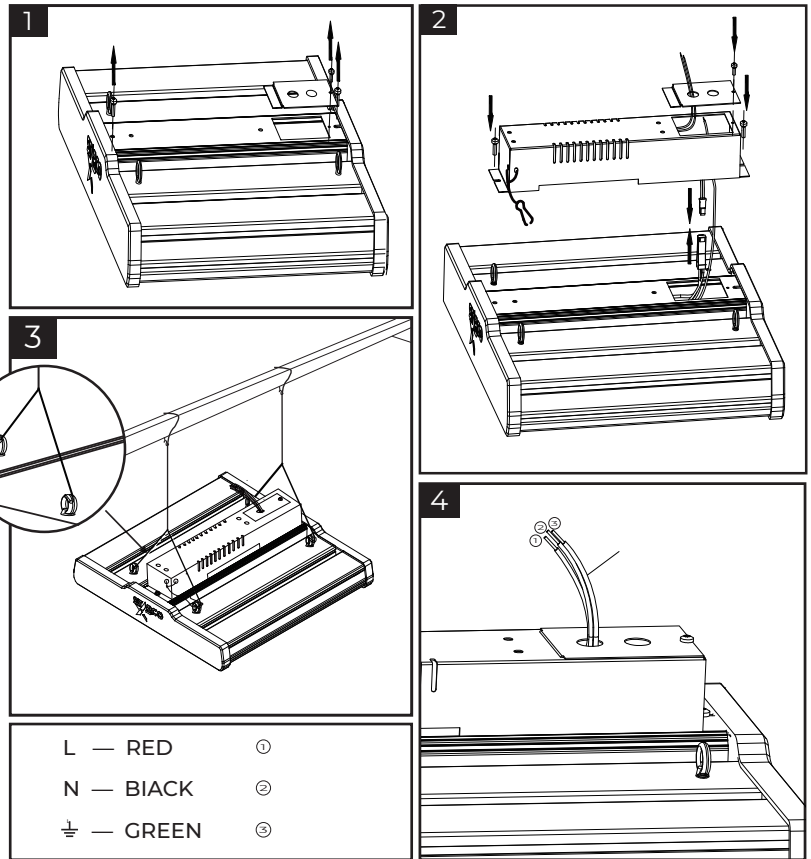

Surface Mount Installation

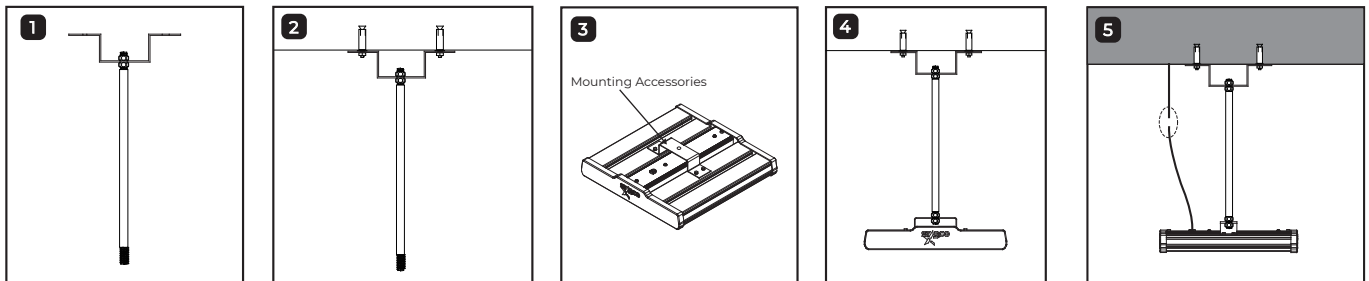

Always turn off the power first.

1. Install the suspending rod with a nut on the bracket.
2. Install the bracket to the ceiling or other mounting surface.
3. Install the mount bracket with screws on the back of fixture.
4. Connect the fixture with the suspending rod.
5. Connect the power cord to the fixture.